



**INSTRUCTION MANUAL FOR
VACUUM CLEANER**

ATX 750-2

THIS IS A CLASS H/ZONE 22 DRY VACUUM CLEANER

PART NUMBER 838624 - 240V, 50-60Hz, 1.0kW
PART NUMBER 838725 - 220V, 50-60Hz, 1.0Kw



UNIT TYPES ARE ALL EARTH BONDED

THE ABOVE UNITS ARE ATEX CERTIFIED

CE **Ex** II 3 D Ex tD A22 IP64 T100°C (ATEX Cert Code)

CAUTION: READ THE INSTRUCTION MANUAL BEFORE USING THE APPLIANCE

PLEASE RETAIN FOR FUTURE REFERENCE

Normal operating temperature range 10 to 30°C





INDEX

Pg 1-11



Pg12-22



Pg23-31



Pg32-41

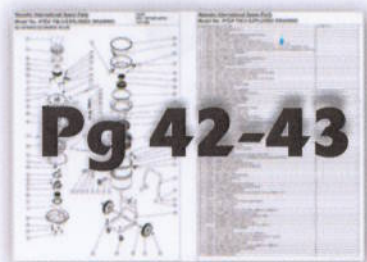

Pg 42-43

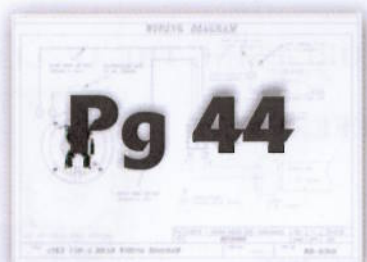

Pg 44

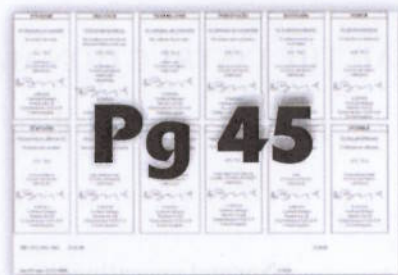

Pg 45

ATEX Certification code defined:

CE Ex II 3 D Ex tD A22 IP64 T100°C



The CE mark



The EX symbol identifies the product is suitable to be used in a potentially explosive environment (dust only for this appliance)

II

Equipment group II (surface industries)

3

Category 3 product

D

Explosive dust atmosphere

Ex

Assessed against European Harmonised standards

tD

Protection by preventing dust ingress

A22

Indicates the appliance can be used in a Zone 22 area with conductive dusts

IP64

Dust tight with no ingress of dust (electrical compartment)
Protected against water spray from all directions,
limited ingress permitted.

T100°C

Surface temperature for dust evaluation is less than 100°C

Normal operating temperature range +10 to +30°C

ATEX RISK ASSESSMENT

To ensure this appliance is used in the appropriate area (Zone 22), a formal risk assessment **must** be carried by a competent person or certified body in order to meet the latest ATEX 137 Directive 1999/92/EC. Visit www.hse.gov.uk (for the UK only)

Always refer to material data sheets, and national health and safety legislation

The Risk Assessment is the responsibility of the employer, customer or end user and should take into account, but not be limited to the characteristics of the materials being collected:

1. Spark ignition sensitivity
2. Hot surface ignition sensitivity (cloud)
3. Hot surface ignition sensitivity (layer/depth)
4. Thermal instability
5. Chemical instability
6. Static electricity generation
7. Explosion severity
8. Flammable gas generation
9. Impact of collected materials
10. Burning behaviour
11. The ATEX certification code for the appliance being assessed
12. For dusts with ignition energy less than 1mJ additional restrictions of the labour authorities may apply

IMPORTANT USER INFORMATION

This appliance is designed to be used in a Class H/ATEX Zone 22 D (dust) environment and has three levels of vacuum filtration. Dust is collected in a paper bag. It is designed to pick-up:

1. Inert dust and debris in an atmosphere where flammable dust, gases or vapours, are **never** present (conventional vacuum cleaner)
2. Inert dust and debris in a Zone 22 D area
3. Potentially explosive dust and debris in a Zone 22 D area

Before use operators should be provided with information, instruction and training for the use of the appliance and the substances for which it is to be used, including the safe method of disposing of material collected. See ATEX RISK ASSESSMENT (see page 3)

This appliance is not intended for use by persons (including children) with reduced physical sensory or mental capabilities, or lack of experience and knowledge

Children should be supervised to ensure that they do not play with the appliance

The dust container has to be emptied when necessary, but also after every use

This vacuum cleaner emits an audible alarm when air velocity drops below a preset level, which indicates that the bag must be changed

During **abnormal** operation surface temperatures may rise to T100 max °C

This appliance is **only** suitable for pick-up of **dry** dusts and debris (not designed for liquids)

Type 22 appliances are **not** suitable to pick up dusts or liquids of high explosion risk, nor mixtures of combustible dusts with liquids

This appliance is **not** suitable for connection with dust generating machines

All filters including the bag must be undamaged and in correct position before this appliance can be used safely

This appliance is suitable for commercial use e.g. in hotels, schools, hospitals, factories, shops, offices and rental businesses

CAUTION: This appliance is designed to be used in an area where dust may exist for limited periods of time

CAUTION: This appliance is for dry use only and is not to be used or stored outdoors in wet conditions

Do not pick up glowing embers or dust or any other ignition hazard

Do not use the power cable as a method of moving the appliance

Do not use mains extension cables with this appliance

Never use in an area where flammable gases or vapours may exist

Do not allow floors to come into contact with the supply cord

WARNING: Only use the accessories approved by the appliance manufacturer for Type 22 use. The use of other accessories may cause an explosion hazard

WARNINGS

1. This appliance must only be operated by suitably trained and authorised personnel
2. This appliance or its accessories must not be modified
3. The appliance must not be stored or used in a wet environment
4. Empty the vacuum cleaner bag every time when collecting potentially explosive dust or debris
5. Do not cover the air vent louvers on the head assembly
6. Do not allow the dust collection bag (NVM-4) to become so full as to reduce the effective pick-up of the vacuum (audible alarm will sound at preset air velocity levels)
7. Only use the dust collection bag (NVM-4) once
8. This appliance must only be repaired by suitably trained and authorised personnel
9. Only use genuine Numatic International Ltd spare parts, for repairs
10. The filtration system on this appliance must only be configured as shown in these instructions (see figure 1)
11. This appliance must not be installed as a fixed extraction system or run unattended
12. The earth continuity between pick-up nozzle and electrical cable earth need to be checked on a regular basis, by a competent person and records kept (Resistance must be less than 1 Giga ohm (10^9 ohms))

PREPARATION FOR USE

Unpack and identify each item of equipment from the delivery note

Check that the details given match the information on the "rating plate" mounted on the Head Assembly

ELECTRICAL CONNECTIONS FOR 240 & 220V VERSIONS

The supply for these appliances must be fitted with suitable fuse or protective device to meet the current demands.

In order to utilise the appliance in a dust explosive atmosphere an ATEX certified plug (Zone 22 D (Dust)) **MUST** be fitted and a corresponding socket selected, otherwise the plug and socket **MUST** be in an area known to be safe

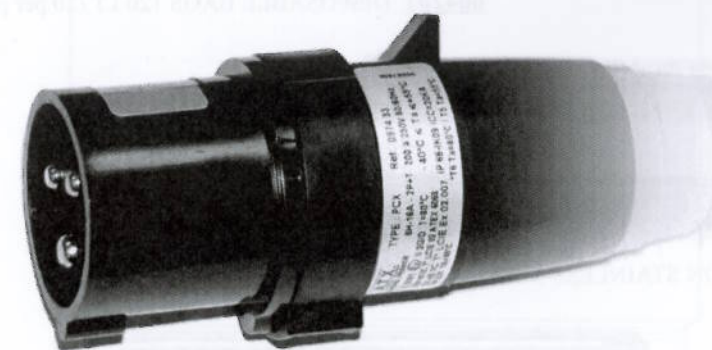

ATEX 750-2 ACCESSORY KIT LIST - 607264

- 602111 HOSE ASSEMBLY 38mm ATEX - 1 per
- 602112 BRUSH NOZZLE 400mm WIDE TRACK ATEX - 1 per
- 602919 TUBE BEND STAINLESS STEEL (NVB-19B) - 1 per
- 602929 TUBE EXTENSION STAINLESS STEEL - 2 per
- 602923 GULPER/SCRAPER 305mm STAINLESS STEEL - 1 per
- 604104 DUST BAGS (NVM-4B) (10 per packet) 1 pkt
- 604201 DISPOSABLE BAGS 120 LT (20 per packet) 1 pkt



602112 BRUSH NOZZLE 400mm WIDE TRACK ATEX - 1 per

602111 HOSE ASSEMBLY 38mm ATEX - 1 per



604104 DUST BAGS (NVM-4B) (10 per packet) 1 pkt



602919 TUBE BEND STAINLESS STEEL (NVB-19B) - 1 per



604201 DISPOSABLE BAGS 120 LT (20 per packet) 1 pkt

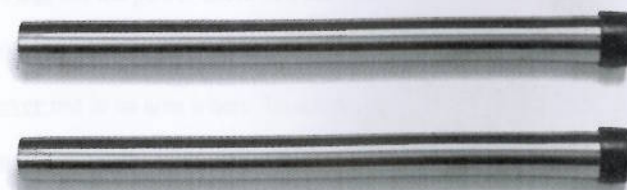

602929 TUBE EXTENSION STAINLESS STEEL - 2 per



602923 GULPER/SCRAPER 305mm STAINLESS STEEL - 1 per

ATEX 750-2 SECTIONAL VIEW

(Figure 1)

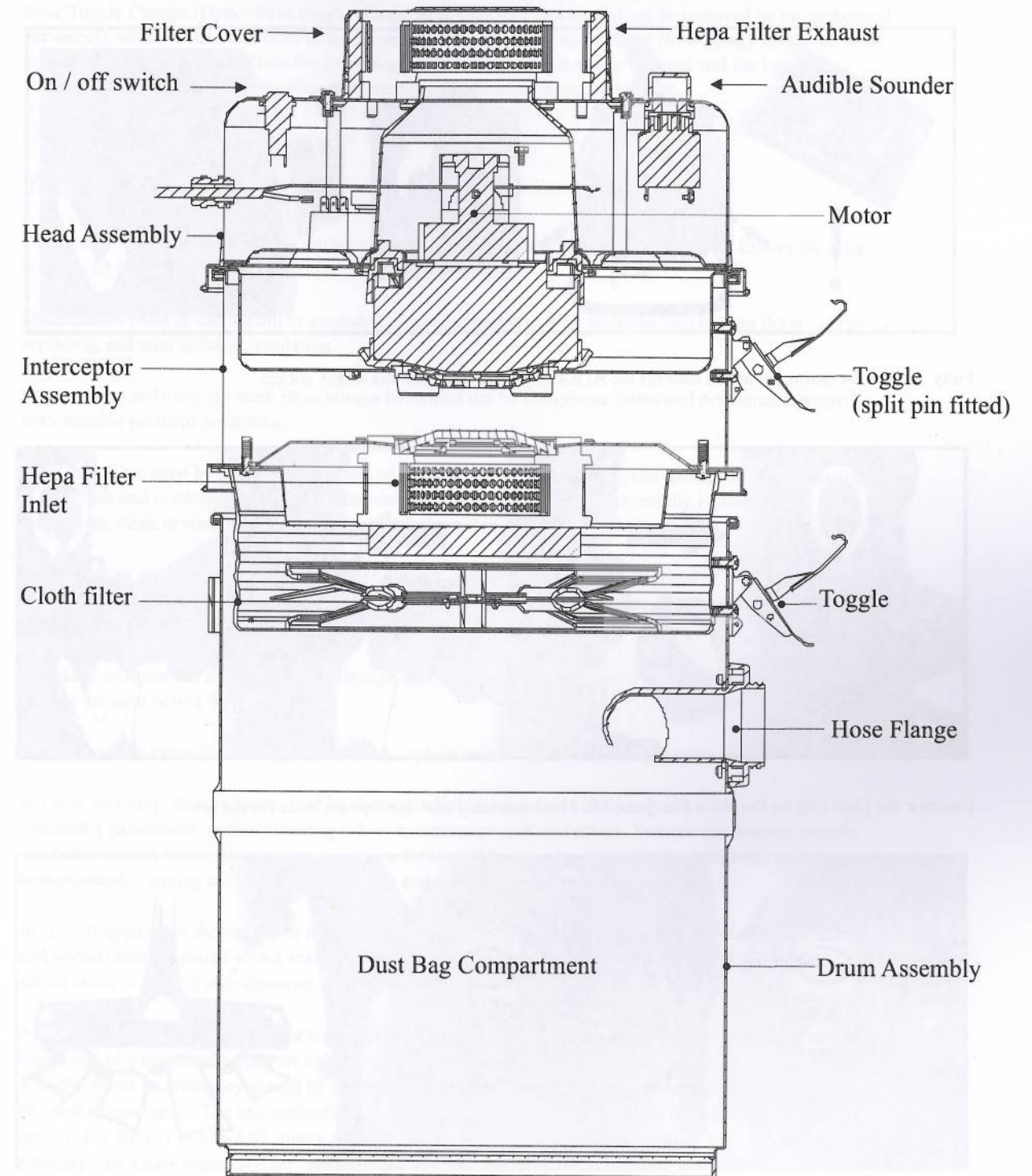

PREPARING APPLIANCE FOR NORMAL USE

Ensure the dust bag (NVM-4B) has been properly fitted over Hose Flange internally by unclipping the three lower toggle clamps, and lifting off Head & Interceptor assembly. If not fitted, fully insert dust bag over Hose Flange and re-fit the Head & Interceptor assembly

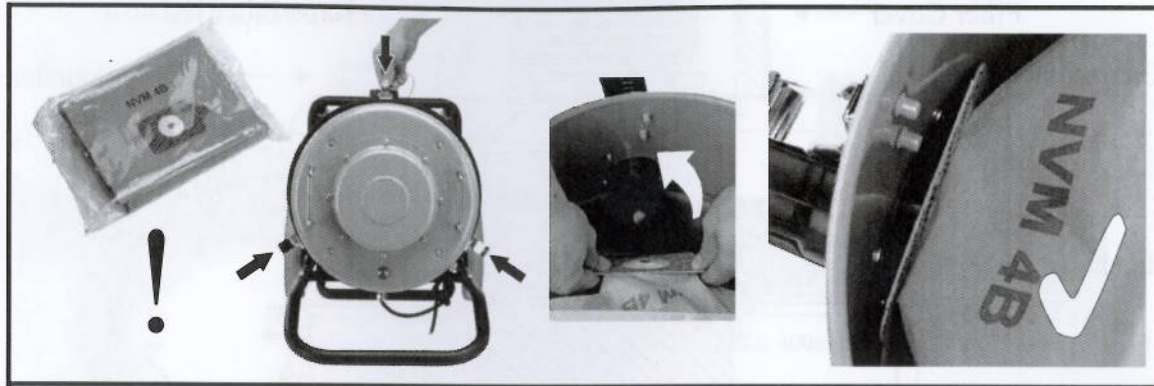

Fully unwind the mains cable and connect the ATEX approved plug into the ATEX socket

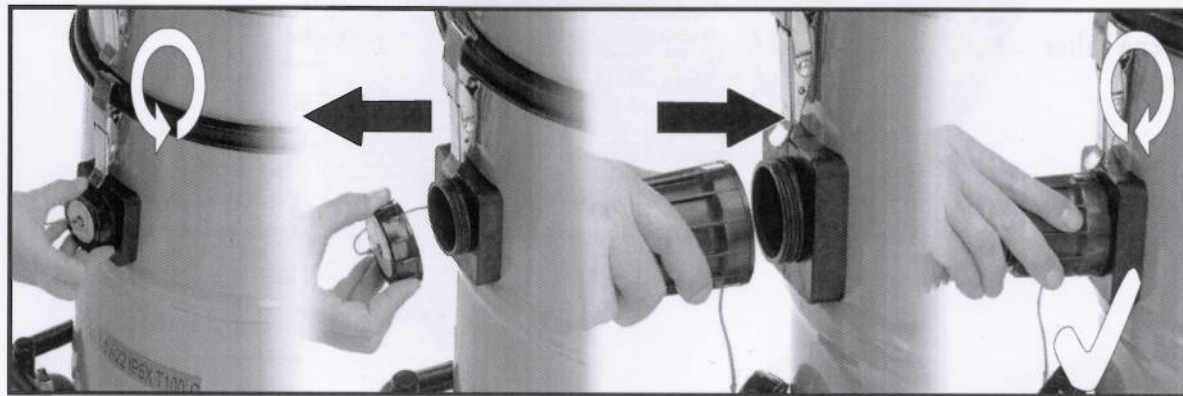

Unscrew the Dust Cap on the Hose Flange and fit Hose assembly plus appropriate tools for the job

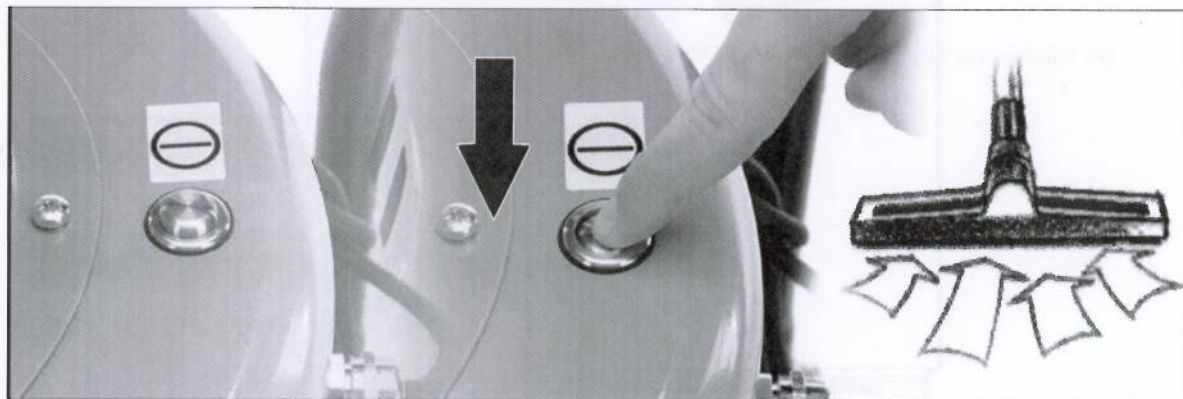

To run the appliance, press the ON/OFF button in. Press once for ON, then press again for OFF

DISPOSAL

The dust bag holding the dust and debris must be removed and renewed by authorised personnel, wearing appropriate personnel protection, in a specified contamination area. Never operate without the full filtration system in place.

Process of disposal: Disconnect the hose, fit the Dust Cap on the Hose Flange, un-clip the bottom three Toggle Clamps (Upper three toggle clamps have split pins that should not be removed by un-authorised personnel). Remove the cloth filter in the Drum. Remove the dust bag from the Hose Flange inside the drum and seal the Dust Bag hole. Place the Dust Bag inside an impervious plastic bag and seal the bag. Dispose of the plastic bag, depending on contamination, in an appropriate manner.

Fit a new Dust Bag over the Hose Flange inside the drum assembly. Refit the cloth filter, and the Head, plus Interceptor assembly, re-applying the 3 Toggle clamps.

MAINTENANCE

Disconnect from the power supply during cleaning, maintenance or when replacing parts. Ensure the plug is removed from the socket outlet.

Maintenance must be carried out in a suitable non hazardous area with facilities for cleaning the area after servicing, and with suitable ventilation.

Maintenance and cleaning work must always be carried out by competent authorised personnel equipped with suitable personal protection.

The Cloth filter must be taken out and checked for degree of contamination, and damage to cloth or seals. If the Cloth seal is damaged or badly contaminated, you must replace. If only mildly contaminated, either wipe clean or wash with a mild detergent (ensure it is dry before replacing).

Items that can not be satisfactorily cleaned (e.g. filters) then they need to be disposed of in an impervious plastic bag and disposed of in accordance with current regulations. Replace the items that cannot be satisfactorily cleaned using approved manufacturer parts

Regularly examine the supply cord for damage, such as cracking or ageing. If damage is found, replace the cord before further use

All parts of this vacuum are safety critical only replace with the genuine Numatic spare parts

For user servicing, the appliance must be dismantled, cleaned and serviced, as far as is reasonably practicable, without causing risk to maintenance staff and others. Suitable precautions include decontamination before dismantling, provision for local filtered exhaust ventilation where the appliance is dismantled, cleaning of the maintenance area and suitable personal protection

In class H appliances the outside of the appliance should be decontaminated by vacuum cleaning methods and wiped clean or treated with a sealant before being taken out of the hazardous area and appropriate action taken to prevent dust dispersal. (HSE Risk Assessment needed).

A competent person shall perform a technical inspection at least annually, consisting of, for example, inspection of filters for damage, air tightness of the appliance and proper function of the control mechanism. Also the filtration efficiency should be tested at least annually, or more frequently as specified in national requirements. The test methods that can be used to verify the appliance's filter efficiency are specified in BE EN 60335-2.69 Annex AA (AA22.201.2). If the test fails it should be repeated with a new essential filter.

The earth continuity between pick-up nozzle and electrical cable earth need to be checked on a regular basis, by a competent person and records kept (Resistance must be less than 1 Giga ohm (10^9 ohms))

Replacing HEPA filters process:

HEPA filter INLET (see figure 1)

Unclip the top three toggle clamps, removing the security split pins in advance. Remove the Head assembly and place in a safe area. Unclip the lower three toggle clamps and remove the Interceptor assembly from the Drum assembly, and place the Interceptor on a good level working surface. Unscrew the 6, M5 x 10 screws on the underside of the Interceptor assembly which will expose the HEPA filter.

Remove the contaminated HEPA filter and place in a suitably impervious plastic bag and dispose of in accordance with current regulations. Replace the HEPA filter with an identical approved part (ensure plastic filter grid that locates into the hole in the metalwork is not thrown away with HEPA filter). Re-assemble the Interceptor assembly in reverse order. If the seal between the upper and lower metal parts of the Interceptor assembly is damaged, replace with a manufacturer approved seal material (there must be **NO** gap in the circular seal).

Re-assemble the appliance in reverse order. (Screw torque 2.5Nm). Ensure new split pins are fitted and legs opened

During this process please look carefully at all seals between mating parts and check for any damage. If seals have been damaged, please contact the appliance manufacturer to obtain an approved replacement part.

HEPA filter EXHAUST (see figure 1)

Unscrew the 8, M5 X 10 screws holding the Filter Cover onto the Head assembly. Remove Filter Cover to expose HEPA filter. Remove the contaminated HEPA filter and place in a suitably impervious plastic bag and dispose of in accordance with current regulations. Replace the HEPA filter with an identical approved part. Re-assemble the Filter Cover onto the Head Assembly, trapping the HEPA filter, tightening up all screws (Screw torque 2.5Nm)



SPARES

In order to ensure that the maintenance work can be carried out without delay, we recommend that stocks of the following parts are held:



Atex Hepa filter
604023



Filter cloth assembly (anti-static)
502033



Filter bags (pack of 10)
604104

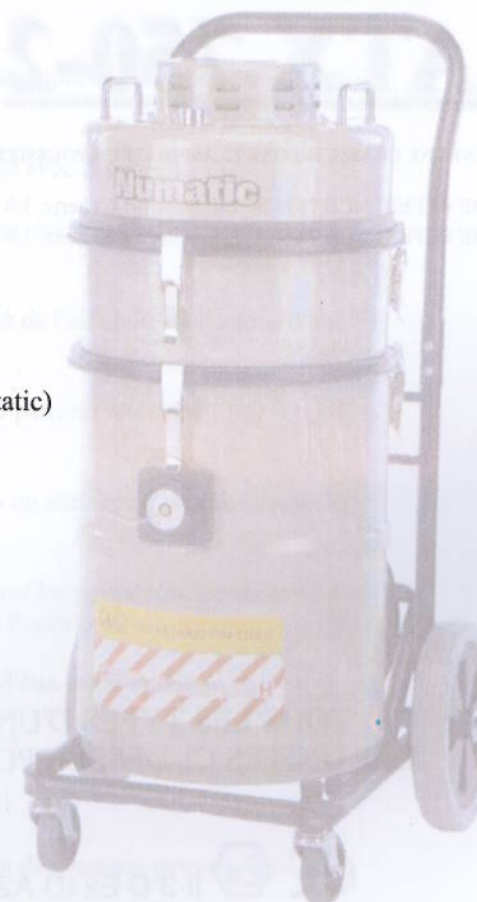

DATA:

Noise	Suction	Airflow	Dry Capacity	Weight	Size	Cleaning Range
72.2db@1m	248 mbar	35.7 l/s	35 Litres	22Kg	510x510 x960	13.5m