

Sprinter



- Suitable to work in high congested areas like small shops, offices, kitchens, schools, hospitals, bars, gyms, restaurants
- Three controls for brush drive, washing and drying operations
- Double floor squeegee for both forward and reverse drying
- Sound pressure 68 dB (A)
- Min. working height required 200 mm
- Structure built with durable materials
- Suitable load on the brush for an optimal cleaning efficiency
- Detachable detergent/recovery tank
- Cable holder
- 7mt electric cable
- Non-marking wheels.

Standard equipment:



- 6.505.0002
PPL brush Ø 100 mm



- 6.505.0001
Squeegee kit



- 5.509.0007
Stationary plate



- 0.010.0034
4 x 100 ml concentrated detergent



Watch the video on youtube:
www.youtube.com/lavorpro

	Sprinter
code	8.501.0501
power supply	230 V - 50 Hz
scrubbing / squeegee width	290 / 320 mm
max working capacity	1015 m ² /h
detergent tank capacity	2.8 l / 0.74 gal
recovery tank capacity	5.6 l / 1.48 gal
traction	mechanical
RPM / pressure on the brushes	1000 / 7 kg / 15,43 lbs
brush motor power	200 W
noise level dB (A)	68
depression / vacuum motor	1428 mmH ₂ O / 800 W
dimensions / weight	37 x 37 x 113 cm / 13 kg

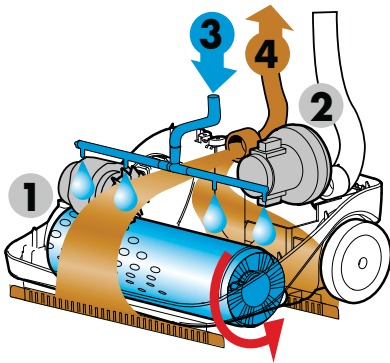

- 1) Brush motor
- 2) Vacuum motor
- 3) Detergent solution flow
- 4) Dirty liquid flow

Double squeegee for both forward and reverse washing and drying.
 PPL brush suitable for most common floors (brush for carpet and moquette cleaning available).
 ABS shock-proof covers. Non-marking rubber wheels.

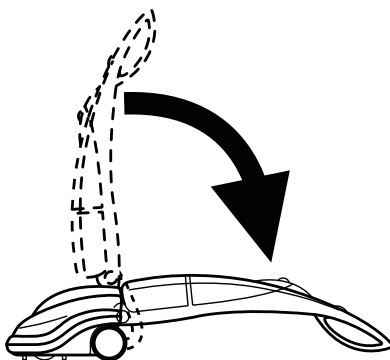

Minimum working height 200 mm, allowing perfect cleaning under furnitures, chairs, tables, beds, etc.
 The tilting handle makes easy and stressless the daily use of the machine.
 Large tank capacity avoiding frequent refilling of the unit

Cylindrical brush quick connection and release: the fitting and releasing of the brush does not require the use of tools. Ordinary cleaning and maintenance are simple and quick for anybody



Optional accessories:



- 6.605.0009
Carpet cleaning kit



- 4.512.0068
Extension electric cord 15 m with Schuko plug



- 0.010.0014
64 x 100 ml concentrated detergent